

PMT.100 Indexing plungers

SUPER-technopolymer body

INCH

SUPER TECHNO POLYMER

INOX STAINLESS STEEL

RoHS

PA

+266 °F
-22 °F

- 1
- 2
- 3
- 4
- 5
- 6
- 7
- 8
- 9
- 10
- 11
- 12
- 13
- 14
- 15
- RH

THREADED BODY

Glass-fibre reinforced polyamide based (PA) SUPER-technopolymer.

PLUNGER

Black-oxide hardened steel or AISI 303 stainless steel.
Suggested tolerance for matching hole = H7.

KNOB

High-resilience polyamide based (PA) technopolymer, black colour or RAL 3000 red colour (C6), matte finish.

SPRING

AISI 302 stainless steel.

LOCKING NUT (NTT)

Glass-fibre reinforced polyamide based (PA) SUPER-technopolymer.
Available also as accessory sold separately (see table NTT).

STANDARD EXECUTIONS

- **PMT.100-A:** black-oxide steel plunger, without locking nut.
- **PMT.100-AK:** black-oxide steel plunger, with locking nut (supplied not assembled).
- **PMT.100-SST-A:** AISI 303 stainless steel plunger, without locking nut, not magnetic.
- **PMT.100-SST-AK:** AISI 303 stainless steel plunger, with locking nut (supplied not assembled), not magnetic.

FEATURES AND APPLICATIONS

- Lightness and high mechanical resistance of the product.
- The SUPER-technopolymer threaded body of the plunger offers a low friction factor to the plunger stroke; no lubricating maintenance is required.
- Anticorrosive material: suitable even in the presence of liquid or humidity (PMT.100-SST).
- Resistant to several cleaning cycles with solvents and other chemical agents, for this reason they are suitable for applications as in the pharmaceutical or food industry.

ASSEMBLY INSTRUCTIONS

Make sure that no machining residues are left on the threaded hole for the assembly of PMT.100 indexing plunger (see fig. 1). Do not make any chamfering in the hole (see fig. 2).

SUPER-technopolymer product based on ELESA technology, dimensions according to GN 617 standards as agreed with Otto Ganter GmbH Co. KG.

ANOTHER STANDARD EXECUTION

PMT.101: indexing plungers with rest position.



ELESA Original design

Fig.1

Fig.2

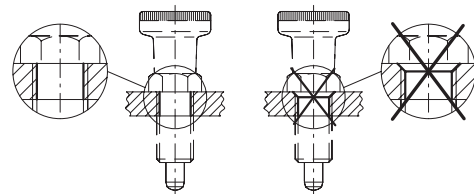

INCH

NTT

Code	Description
90301083	NTT-3/8-24
90301085	NTT-1/2-20
90301087	NTT-5/8-18

Indexing and positioning elements

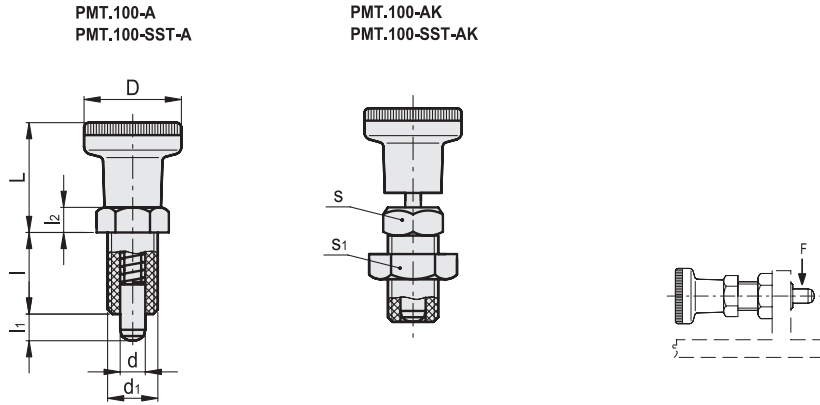

PMT.100

INCH

Code	Description	d-0.15-0.1	d1	L	D	l	l1	l2	s	s1	*	#	Maximum tightening torque [ft·lb]	Static load at breakage F [lbf]	⚖
951501	PMT.100-5-3/8-24-A	0.2	3/8-24	0.91	0.83	0.67	0.2	0.2	0.47	-	2	4	4	515	0.03
951501-C6	PMT.100-5-3/8-24-A-C6	0.2	3/8-24	0.91	0.83	0.67	0.2	0.2	0.47	-	2	4	4	515	0.03
951502	PMT.100-6-1/2-20-A	0.24	1/2-20	1.1	0.98	0.79	0.24	0.24	0.55	-	2	5	7	784	0.04
951502-C6	PMT.100-6-1/2-20-A-C6	0.24	1/2-20	1.1	0.98	0.79	0.24	0.24	0.55	-	2	5	7	784	0.04
951511	PMT.100-8-5/8-18-A	0.31	5/8-18	1.38	1.22	1.02	0.31	0.31	0.75	-	2	7	13	1322	0.06
951511-C6	PMT.100-8-5/8-18-A-C6	0.31	5/8-18	1.38	1.22	1.02	0.31	0.31	0.75	-	2	7	13	1322	0.06
951521	PMT.100-5-3/8-24-AK	0.2	3/8-24	0.91	0.83	0.67	0.2	0.2	0.47	0.63	2	4	4	515	0.05
951521-C6	PMT.100-5-3/8-24-AK-C6	0.2	3/8-24	0.91	0.83	0.67	0.2	0.2	0.47	0.63	2	4	4	515	0.05
951522	PMT.100-6-1/2-20-AK	0.24	1/2-20	1.1	0.98	0.79	0.24	0.24	0.55	0.75	2	5	7	784	0.07
951522-C6	PMT.100-6-1/2-20-AK-C6	0.24	1/2-20	1.1	0.98	0.79	0.24	0.24	0.55	0.75	2	5	7	784	0.07
951531	PMT.100-8-5/8-18-AK	0.31	5/8-18	1.38	1.22	1.02	0.31	0.31	0.75	0.94	2	7	13	1322	0.11
951531-C6	PMT.100-8-5/8-18-AK-C6	0.31	5/8-18	1.38	1.22	1.02	0.31	0.31	0.75	0.94	2	7	13	1322	0.11

PMT.100-SST

INOX STAINLESS STEEL **INCH**

Code	Description	d-0.15-0.1	d1	L	D	l	l1	l2	s	s1	*	#	Maximum tightening torque [ft·lb]	Static load at breakage F [lbf]	⚖
951551	PMT.100-SST-5-3/8-24-A	0.2	3/8-24	0.91	0.83	0.67	0.2	0.2	0.47	-	2	4	4	403	0.03
951551-C6	PMT.100-SST-5-3/8-24-A-C6	0.2	3/8-24	0.91	0.83	0.67	0.2	0.2	0.47	-	2	4	4	403	0.03
951552	PMT.100-SST-6-1/2-20-A	0.24	1/2-20	1.1	0.98	0.79	0.24	0.24	0.55	-	2	5	7	650	0.04
951552-C6	PMT.100-SST-6-1/2-20-A-C6	0.24	1/2-20	1.1	0.98	0.79	0.24	0.24	0.55	-	2	5	7	650	0.04
951561	PMT.100-SST-8-5/8-18-A	0.31	5/8-18	1.38	1.22	1.02	0.31	0.31	0.75	-	2	7	13	986	0.06
951561-C6	PMT.100-SST-8-5/8-18-A-C6	0.31	5/8-18	1.38	1.22	1.02	0.31	0.31	0.75	-	2	7	13	986	0.06
951571	PMT.100-SST-5-3/8-24-AK	0.2	3/8-24	0.91	0.83	0.67	0.2	0.2	0.47	0.63	2	4	4	403	0.05
951571-C6	PMT.100-SST-5-3/8-24-AK-C6	0.2	3/8-24	0.91	0.83	0.67	0.2	0.2	0.47	0.63	2	4	4	403	0.05
951572	PMT.100-SST-6-1/2-20-AK	0.24	1/2-20	1.1	0.98	0.79	0.24	0.24	0.55	0.75	2	5	7	650	0.07
951572-C6	PMT.100-SST-6-1/2-20-AK-C6	0.24	1/2-20	1.1	0.98	0.79	0.24	0.24	0.55	0.75	2	5	7	650	0.07
951581	PMT.100-SST-8-5/8-18-AK	0.31	5/8-18	1.38	1.22	1.02	0.31	0.31	0.75	0.94	2	7	13	986	0.11
951581-C6	PMT.100-SST-8-5/8-18-AK-C6	0.31	5/8-18	1.38	1.22	1.02	0.31	0.31	0.75	0.94	2	7	13	986	0.11

* Spring preload
Spring maximum load



Indexing and positioning elements